

## Extension kit for R&S Vector Network Analysers

### Characterisation of Nonlinear RF/HF Components in Time and Frequency domain

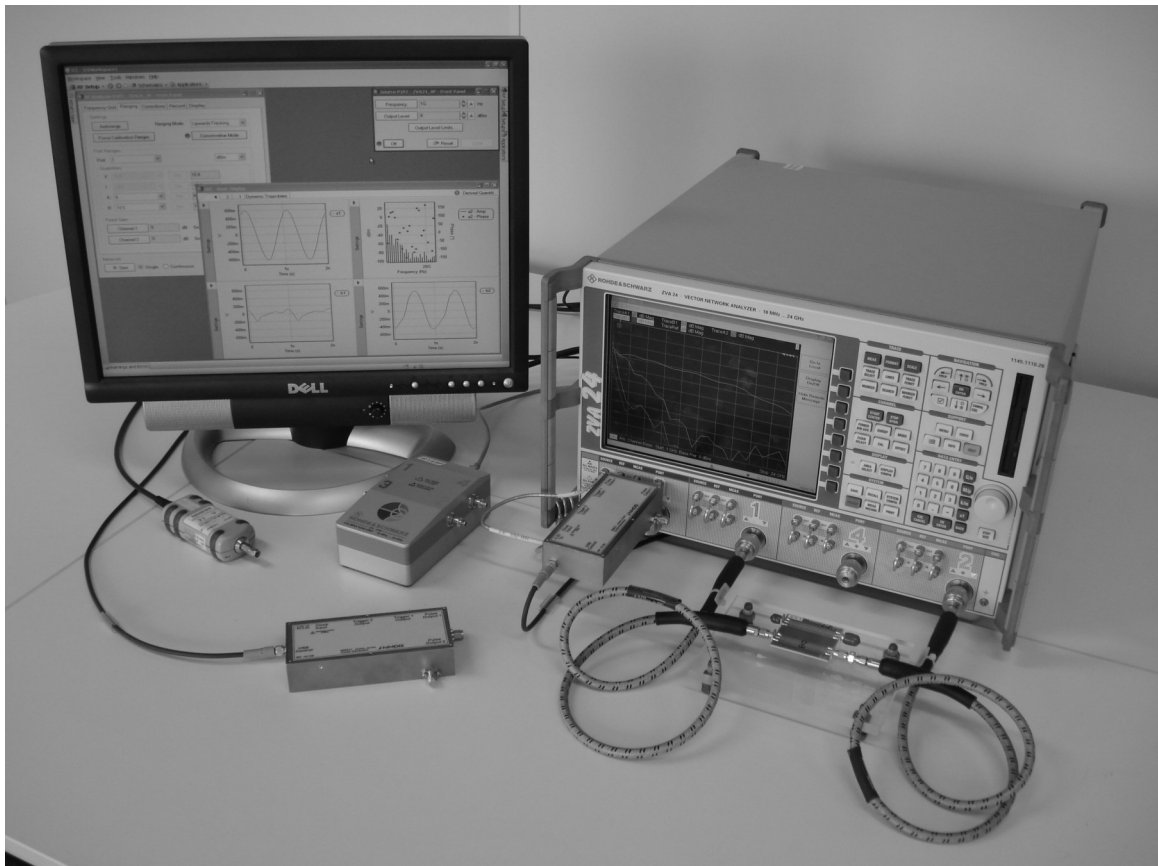



---

# Contents

<b>Introduction</b> .....	<b>7</b>
<b>General block diagram</b> .....	<b>8</b>
<b>Connectivity</b> .....	<b>11</b>
<b>NM211 Comb Generator</b> .....	<b>11</b>
<b>NM311 Connection Kit</b> .....	<b>11</b>
<b>Attenuator Kits</b> .....	<b>12</b>
<b>Adapter Kits</b> .....	<b>13</b>
<b>ICE software requirements</b> .....	<b>15</b>
<b>Specifics for ICE software installed on ZVx</b> .....	<b>15</b>
<b>Specifications</b> .....	<b>17</b>
<b>Hardware specifications</b> .....	<b>17</b>
<b>ZVA24 Vector Network Analyser</b> .....	<b>17</b>
<i>Overall Specifications for ZVxPlus</i> .....	17
<i>Reflectometers</i> .....	17
<i>Port bias</i> .....	18
<i>Receivers</i> .....	19
<i>Receiver step attenuators (B3x)</i> .....	20
<i>Maximum power level versus receiver attenuation</i> .....	20
<b>ZVT8 Vector Network Analyser</b> .....	<b>21</b>
<i>Overall Specifications for ZVxPlus</i> .....	21
<i>Reflectometers</i> .....	21
<i>Port bias</i> .....	21
<i>Receivers</i> .....	22
<i>Maximum power level versus receiver attenuation</i> .....	23
<b>ZVA40 Vector Network Analyser</b> .....	<b>24</b>
<i>Overall Specifications for ZVxPlus</i> .....	24
<i>Reflectometers</i> .....	24
<i>Port bias</i> .....	24
<i>Receivers</i> .....	25
<i>Receiver step attenuators (B3x)</i> .....	25
<i>Maximum power level versus receiver attenuation</i> .....	26
<b>ZVA50 Vector Network Analyser</b> .....	<b>27</b>
<i>Overall Specifications for ZVxPlus</i> .....	27
<i>Reflectometers</i> .....	27
<i>Port bias</i> .....	27
<i>Receivers</i> .....	28
<i>Receiver step attenuators (B3x)</i> .....	29
<i>Maximum power level versus receiver attenuation</i> .....	29
<b>ZVA67 Vector Network Analyser</b> .....	<b>30</b>
<i>Overall Specifications for ZVxPlus</i> .....	30
<i>Reflectometers</i> .....	30
<i>Port bias</i> .....	30
<i>Receivers</i> .....	31
<i>Receiver step attenuators (B3x)</i> .....	32

---

<i>Maximum power level versus receiver attenuation</i> .....	32
NM211 Comb Generator.....	33
Power supply (included) : 230 V / 50 Hz – 110 V / 60 Hz – 18VA.....	33
<b>Additional Hardware</b> .....	<b>35</b>
<b>Supported equipments</b> .....	<b>35</b>
DC Sources (including DC Voltage and Current Meters).....	35
DC Voltage and Current Meters.....	35
RF Sources.....	36
Power Meters.....	36
Calibration Units.....	37
Tuners.....	37
<b>Customization</b> .....	<b>37</b>
Instrument drivers.....	37
External Test sets.....	37
<b>Order Information</b> .....	<b>39</b>
<b>Trademark Information</b> .....	<b>41</b>
<b>Contact Information</b> .....	<b>43</b>





# Introduction

The NM310 is a combination of additional hardware and software that runs on top of a selection of ZVA and ZVT vector network analysers (VNA) from Rohde&Schwarz. The combination of the ZVx and the NM310 extension kit is referred to as “ZVxPlus”.

On top of the standard measurement capabilities of the R&S VNA, the ZVxPlus provides calibrated measurement capability of the time waveforms of the incident and reflected waves or voltages and currents at the ports of a component under test. The time waveforms are periodic with a minimal frequency of 20 MHz and with spectral components up to 24 GHz.

The NM310 kit consists of:

- 1x NM211 Comb Generator used as synchronizer 20MHz-24GHz
- 1x NM211 Comb Generator used as Harmonic Phase Reference 20MHz-24GHz
- 1x NM311 3.5mm Connection Kit
- 1x ICE Software License
- One year warranty and support

This kit runs on top of the 4-port R&S®ZVA8/24/40/50/67 and on top of the R&S®ZVT8/20 (at least 3 ports), with the following options:

- Direct generator/receiver Access option (R&S®ZVAxx-B16 or R&S®ZVTxx-B16)
- Frequency conversion option (R&S®ZVA-K4)
- Optional: step attenuator option for measurement receivers at Port 1 and Port 2, allowing automatic range adaptation (R&S®ZVAxx-B31 and -B32 or R&S®ZVTxx-B31 and -B32)

A 2.4mm to 3.5mm adapter option is offered for the NM311 Connection Kit on the R&S®ZVA50 and ZVA67.

When the step attenuator option on Port 1 (option B31) and/or Port 2 (option B32) is missing, one needs to put external attenuators in front of the corresponding measurement receiver. Attenuator and adapter kits are then offered per port, depending on the selected VNA and the desired frequency range.

# General block diagram

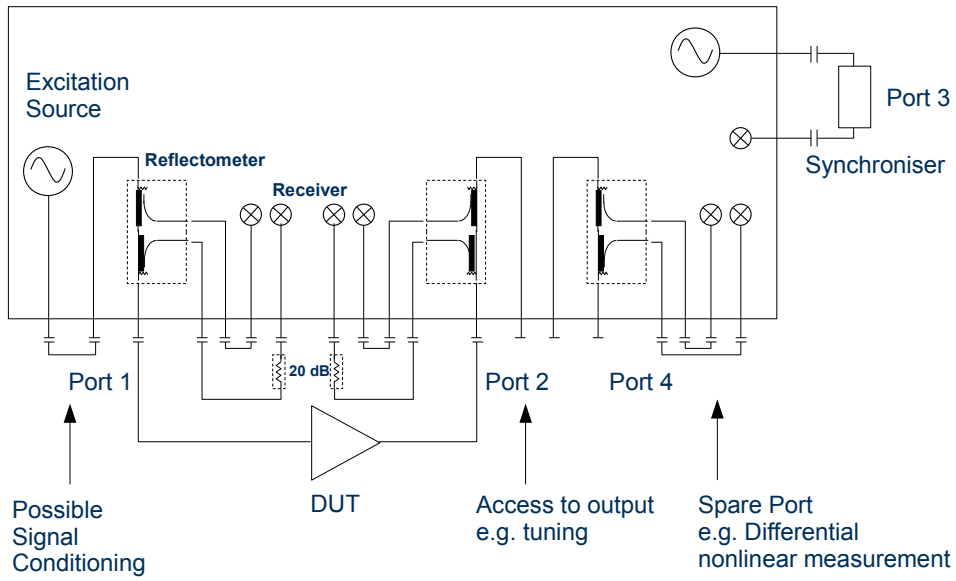

*Block diagram of ZVxPlus for the different R&S VNAs*





# Connectivity

## NM211 Comb Generator

Input port connector	SMA, female
Output port 2 connector	2.92 mm, male
Trigger port 1 connector	SMA, female
Trigger port 2 connector	SMA, female
USB control port	USB Type B

## NM311 Connection Kit

3x semi-rigid cables (Synchroniser)	
Input port connector	3.5 mm, male
Output port connector	3.5 mm, male
1x flexible cable (Harmonic Phase Reference)	
Input port connector	SMA, male
Output port connector	SMA, male
2 x adapters	
Input port connector	3.5 mm, female
Output port connector	3.5 mm, female
1x 4-port USB hub	

## Attenuator Kits

<p>NM302 20GHz Attenuator Kit for R&amp;S@ZVT8/20 / R&amp;S@ZVA24/50/67*</p> <p>1x 20GHz Connection Loop          Input port connector          Output port connector</p> <p>3x 20GHz (6dB, 10dB &amp; 20dB) Attenuators          Input port connectors          Output port connectors</p>	<p>3.5 mm, male          3.5 mm, male</p> <p>3.5 mm, female          3.5 mm, male</p>
<p>NM304 40GHz Attenuator Kit for R&amp;S@ZVA40*</p> <p>1x 40GHz Connection Loop          Input port connector          Output port connector</p> <p>3x 40GHz (6dB, 10dB &amp; 20dB) Attenuators          Input port connectors          Output port connectors</p>	<p>2.92 mm, male          2.92 mm, male</p> <p>2.92 mm, female          2.92 mm, male</p>
<p>NM305 50GHz Attenuator Kit for R&amp;S@ZVA50/67*</p> <p>1x 50GHz Connection Loop          Input port connector          Output port connector</p> <p>3x 50GHz (6dB, 10dB &amp; 20dB) Attenuators          Input port connectors          Output port connectors</p>	<p>2.4 mm, male          2.4 mm, male</p> <p>2.4 mm, female          2.4 mm, male</p>

\* Required per port without internal step attenuator option (options B31 and/or B32)

## Adapter Kits

<p>NM311A 2.4mm Adapter Kit for NM311 on R&amp;S®ZVA50/67</p> <p>3x Adapters              Input port connector              Output port connector</p> <p>1x Adapter              Input port connector              Output port connector</p>	<p>2.4 mm, male          3.5 mm, female</p> <p>2.4 mm, male          3.5 mm, male</p>
<p>NM302A 2.4mm Adapter Kit for NM302 on R&amp;S®ZVA50/67*</p> <p>2x Adapters              Input port connector              Output port connector</p>	<p>2.4 mm, male          3.5 mm, female</p>

\* Required per port without internal step attenuator option (options B31 and/or B32)



# ICE software requirements

Please refer to the [NMDG Software Requirements](#) document, for general information about the requirements.

## Specifics for ICE software installed on ZVx

External equipments control Required ZVx accessories	R&S®ZVAB-B44 Option
Installed software .NET Framework	.NET Framework 2.0 SP2*
Recommended accessories External display	Minimal resolution 1024 x 768 Recommended resolution 1280 x 1024

\* The ICE software installer will automatically install this in case it is missing otherwise.



# Specifications

## Hardware specifications

### ZVA24 Vector Network Analyser

#### *Overall Specifications for ZVxPlus*

Frequency range	20 MHz – 24 GHz	limited by NM211
Minimal frequency grid spacing	20 MHz	

#### *Reflectometers*

Insertion loss	<7 dB, typ. 5dB	
Return loss	>8 dB, typ. 15 dB	
Coupling factor in Reference channel	typ. 14 dB	18dB @ 600MHz
in Measurement channel	typ. 12 dB	15dB @ 600MHz
Directivity	>40dB	
Damage power level	+27 dBm	
Damage DC voltage	30 V	

## Specifications

---

### *Port bias*

Maximum nominal input voltage	30 V	
Maximum nominal input current	200 mA	
Damage voltage	30 V	
Damage current	500 mA	

**Receivers**

<b>Noise floor</b>  Reference receiver channel  IF BW:      100 kHz      -61 dBm 10 kHz      -71 dBm 1 kHz        -81 dBm 100 Hz      -91 dBm 10 Hz        -101 dBm  Measurement* receiver channel  IF BW:      100 kHz      -68 dBm 10 kHz      -78 dBm 1 kHz        -88 dBm 100 Hz      -98 dBm 10 Hz        -108 dBm		@ Test port
<b>Compression</b>  Reference receiver channel Odd harmonics only      +26 dBm All harmonics              +6 dBm  Measurement* receiver channel Odd harmonics only      +27 dBm All harmonics              +12.5 dBm		@ Test port  60 dBc SFDR** 60 dBc SFDR**  60 dBc SFDR** 60 dBc SFDR**
<b>Cross talk</b>  from Reference to Measurement receiver      None  from Measurement to Reference receiver      -80 dB		
<b>Damage power level</b>	+20 dBm	
<b>Damage DC voltage</b>	0V	

\* Including 25 dB Attenuator

\*\* Spurious Free Dynamic Range including harmonics

## Specifications

### *Receiver step attenuators (B3x)*

Attenuation	0 dB to 35 dB	
Attenuation steps	5 dB	
Attenuation accuracy	<2 dB	
Systematic amplitude error	typ. 0.5 dB	
Systematic phase error*	5°	

\* After nominal delay compensation

### *Maximum power level versus receiver attenuation*

Attenuation	Reference receiver	Measurement receiver	
	Maximum power @ Source Input (Odd harm. Only/All harm.)	Maximum power @ Test Port (Odd harm. Only/All harm.)	
	External attenuator	External attenuator (25 dB included)	Internal step attenuator (B3x)
0 dB	+26 / +6 dBm	+27 / +12.5 dBm	+4.5 / -12.5 dBm
5 dB	+27 / +11 dBm	+27 / +17.5 dBm	+9.5 / -7.5 dBm
10 dB	+27 / +16 dBm	+27 / +22.5 dBm	+13.5 / -2.5 dBm
15 dB	+27 / +21 dBm	+27 / +27 dBm	+18.5 / +2.5 dBm
20 dB	+27 / +26 dBm	+27 / +27 dBm	+23.5 / +7.5 dBm
25 dB	+27 / +27 dBm	+27 / +27 dBm	+27 / +12.5 dBm
30 dB	+27 / +27 dBm	+27 / +27 dBm	+27 / +17.5 dBm
35 dB	+27 / +27 dBm	+27 / +27 dBm	+27 / +22.5 dBm

## ZVT8 Vector Network Analyser

### Overall Specifications for ZVxPlus

Frequency range	20 MHz – 8 GHz	limited by NM211
Minimal frequency grid spacing	20 MHz	

### Reflectometers

Insertion loss	<9.5 dB, typ. 8.75 dB	8.5 dB @ 1.2GHz
Return loss	<19 dB, typ. 26 dB	
Coupling factor in Reference channel in Measurement channel	typ. 41 dB typ. 20 dB	
Directivity	>7 dB	
Damage power level	+27 dBm	
Damage DC voltage	30 V	

### Port bias

Maximum nominal input voltage	30 V	
Maximum nominal input current	200 mA	
Damage voltage	30 V	
Damage current	500 mA	

## Specifications

### Receivers

<p>Noise floor</p> <p>Reference receiver channel</p> <p>IF BW: 100 kHz -100 dBm 10 kHz -110 dBm 1 kHz -120 dBm 100 Hz -130 dBm 10 Hz -140 dBm</p> <p>Measurement* receiver channel</p> <p>IF BW: 100 kHz -108 dBm 10 kHz -118 dBm 1 kHz -128 dBm 100 Hz -138 dBm 10 Hz -148 dBm</p>		@ Test port
<p>Compression</p> <p>Reference receiver channel All harmonics +27 dBm</p> <p>Measurement* receiver channel All harmonics +23 dBm</p>		@ Test port, @ 600MHz  60 dBc SFDR**  60 dBc SFDR**
<p>Cross talk</p> <p>from Reference to Measurement* receiver - 88 dB</p> <p>from Measurement* to Reference receiver None</p>		
<p>Damage power level</p>	+20 dBm	
<p>Damage DC voltage</p>	0 V	

\* Including 20 dB Attenuator

\*\* Spurious Free Dynamic Range including harmonics

*Maximum power level versus receiver attenuation*

Attenuation	Reference receiver	Measurement receiver
	Maximum power @ Source Input	Maximum power @ Test Port
	External attenuator	External attenuator (20 dB included)
0 dB	+27 dBm	+23 dBm
5 dB	+27 dBm	+27 dBm

## ZVA40 Vector Network Analyser

### *Overall Specifications for ZVxPlus*

Frequency range	20 MHz – 24 GHz	limited by NM211
Minimal frequency grid spacing	20 MHz	

### *Reflectometers*

Coupling factor		
in Reference channel	typ. 22 dB	17dB @ 600MHz
in Measurement channel	typ. 11 dB	17dB @ 600MHz
Damage power level	+27 dBm	
Damage DC voltage	30 V	

### *Port bias*

Maximum nominal input voltage	30 V	
Maximum nominal input current	200 mA	
Damage voltage	30 V	
Damage current	500 mA	

**Receivers**

Compression		@ Test port, @ 600MHz
Reference receiver channel All harmonics	+27 dBm	60 dBc SFDR**
Measurement* receiver channel All harmonics	+13 dBm	60 dBc SFDR**
Cross talk		
from Reference to Measurement* receiver	None	
from Measurement* to Reference receiver	None	
Damage power level	+20 dBm	
Damage DC voltage	0 V	

\* Including 30 dB Attenuator

\*\* Spurious Free Dynamic Range including harmonics

**Receiver step attenuators (B3x)**

Attenuation	0 dB to 35 dB	
Attenuation steps	5 dB	
Attenuation accuracy	<2 dB	
Systematic amplitude error	typ. 0.4 dB	
Systematic phase error*	7°	

\* After nominal delay compensation

## Specifications

### *Maximum power level versus receiver attenuation*

Attenuation	Reference receiver	Measurement receiver	
	Maximum power @ Source Input	Maximum power @ Test Port	
	External attenuator	External attenuator (30 dB included)	Internal step attenuator (B3x)
0 dB	+27 dBm	+13 dBm	-17 dBm
5 dB	+27 dBm	+18 dBm	-12 dBm
10 dB	+27 dBm	+23 dBm	-7 dBm
15 dB	+27 dBm	+27 dBm	-2 dBm
20 dB	+27 dBm	+27 dBm	+3 dBm
25 dB	+27 dBm	+27 dBm	+8 dBm
30 dB	+27 dBm	+27 dBm	+13 dBm
35 dB	+27 dBm	+27 dBm	+18 dBm

## ZVA50 Vector Network Analyser

### *Overall Specifications for ZVxPlus*

Frequency range	20 MHz – 24 GHz	limited by NM211
Minimal frequency grid spacing	20 MHz	

### *Reflectometers*

Coupling factor		
in Reference channel	typ. 22 dB	
in Measurement channel	typ. 10 dB	
Damage power level	+27 dBm	
Damage DC voltage	30 V	

### *Port bias*

Maximum nominal input voltage	30 V	
Maximum nominal input current	200 mA	
Damage voltage	30 V	
Damage current	500 mA	

## Specifications

---

### Receivers

Compression		@ Test port
Reference receiver channel		
Odd harmonics only	+27 dBm	60 dBc SFDR**
All harmonics	+12 dBm	60 dBc SFDR**
Measurement* receiver channel		
Odd harmonics only	+23 dBm	60 dBc SFDR**
All harmonics	+10 dBm	60 dBc SFDR**
Cross talk		
from Reference to Measurement* receiver	None	
from Measurement* to Reference receiver	None	
Damage power level	+20 dBm	
Damage DC voltage	0 V	

\* Including 25 dB Attenuator

\*\* Spurious Free Dynamic Range including harmonics

**Receiver step attenuators (B3x)**

Attenuation	0 dB to 35 dB	
Attenuation steps	5 dB	

**Maximum power level versus receiver attenuation**

Attenuation	Reference receiver	Measurement receiver	
	Maximum power @ Source Input (Odd harm. Only/All harm.)	Maximum power @ Test Port (Odd harm. Only/All harm.)	
	External attenuator	External attenuator (25 dB included)	Internal step attenuator (B3x)
0 dB	+27 / +12 dBm	+23 / +10 dBm	-2 / -15 dBm
5 dB	+27 / +17 dBm	+27 / +15 dBm	+3 / -10 dBm
10 dB	+27 / +22 dBm	+27 / +20 dBm	+8 / -5 dBm
15 dB	+27 / +27 dBm	+27 / +25 dBm	+13 / +0 dBm
20 dB	+27 / +27 dBm	+27 / +27 dBm	+18 / +5 dBm
25 dB	+27 / +27 dBm	+27 / +27 dBm	+23 / +10 dBm
30 dB	+27 / +27 dBm	+27 / +27 dBm	+27 / +15 dBm
35 dB	+27 / +27 dBm	+27 / +27 dBm	+27 / +20 dBm

## ZVA67 Vector Network Analyser

### *Overall Specifications for ZVxPlus*

Frequency range	20 MHz – 24 GHz	limited by NM211
Minimal frequency grid spacing	20 MHz	

### *Reflectometers*

Coupling factor in Reference channel in Measurement channel	typ. 22 dB typ. 10 dB	
Damage power level	+27 dBm	
Damage DC voltage	30 V	

### *Port bias*

Maximum nominal input voltage	30 V	
Maximum nominal input current	200 mA	
Damage voltage	30 V	
Damage current	500 mA	

**Receivers**

Compression		@ Test port
Reference receiver channel Odd harmonics only All harmonics	+27 dBm +12 dBm	60 dBc SFDR** 60 dBc SFDR**
Measurement* receiver channel Odd harmonics only All harmonics	+27 dBm +11 dBm	60 dBc SFDR** 60 dBc SFDR**
Cross talk		
from Reference to Measurement* receiver	None	
from Measurement* to Reference receiver	None	
Damage power level	+20 dBm	
Damage DC voltage	0 V	

\* Including 35 dB Attenuator

\*\* Spurious Free Dynamic Range including harmonics

## Specifications

### *Receiver step attenuators (B3x)*

Attenuation	0 dB to 35 dB	
Attenuation steps	5 dB	

### *Maximum power level versus receiver attenuation*

Attenuation	Reference receiver	Measurement receiver	
	Maximum power @ Source Input (Odd harm. Only/All harm.)	Maximum power @ Test Port (Odd harm. Only/All harm.)	
	External attenuator	External attenuator (35 dB included)	Internal step attenuator (B3x)
0 dB	+27 / +12 dBm	+27 / +11 dBm	+0 / -24 dBm
5 dB	+27 / +17 dBm	+27 / +16 dBm	+5 / -19 dBm
10 dB	+27 / +22 dBm	+27 / +21 dBm	+10 / -14 dBm
15 dB	+27 / +27 dBm	+27 / +26 dBm	+15 / -9 dBm
20 dB	+27 / +27 dBm	+27 / +27 dBm	+20 / -4 dBm
25 dB	+27 / +27 dBm	+27 / +27 dBm	+25 / +1 dBm
30 dB	+27 / +27 dBm	+27 / +27 dBm	+27 / +6 dBm
35 dB	+27 / +27 dBm	+27 / +27 dBm	+27 / +11 dBm

**NM211 Comb Generator**

Frequency range	20 MHz – 24 GHz	< 20 MHz without guaranteed spectrum up to 24 GHz
Drive frequency range	480 MHz – 2.56 GHz	
Divider	1, 2, 4, 8, 16, 32, 64, 128, 256, 512	
Input power range	-6 dBm - +4 dBm	
Input damage level	+6 dBm	
Output peak voltage	-0.5 V <sub>p</sub>	
Pulse width (FWHM)	35 ps	
Min. output power per picket	> -70 dBm	With fundamental of 20 MHz
Amplitude roll-off	< 18 dB	
Max phase deviation	1 degree	
2 $\sigma$ uncertainty at 24 GHz	0.2 degree typical	
Input reflection	< -20 dB typical	
Output reflection	< -10 dB typical < -7 dB typical	20 MHz – 18 GHz 18 GHz – 24 GHz

**Power supply (included) :** 230 V / 50 Hz – 110 V / 60 Hz – 18VA  
-3.3 V, 950 mA



# Additional Hardware

## Supported equipments

### DC Sources (including DC Voltage and Current Meters)

R&S®NGMO series	controlled via its IEC/IEEE-bus interface
Hameg HMP series	controlled via its USB interface
Agilent 662x series	controlled via its IEC/IEEE-bus interface
Agilent DC4142	controlled via its IEC/IEEE-bus interface
Agilent E363xA series	controlled via its IEC/IEEE-bus interface
Keithley 24xx series	controlled via its IEC/IEEE-bus interface
Yokogawa GS610	controlled via its IEC/IEEE-bus interface

### DC Voltage and Current Meters

Hameg HM8112-3	controlled via its USB interface
Agilent 34401A	controlled via its IEC/IEEE-bus interface

## RF Sources

Remark: A 10 MHz clock needs to be shared between the RF source and the ZVx, and the ZVx is set as the master clock.

Internal R&S® ZVx sources	
R&S® SMx100A series <sup>*,**</sup>	controlled via its IEC/IEEE-bus interface
R&S® SMBV100A source <sup>*,**</sup>	controlled via its IEC/IEEE-bus interface
R&S® SMIQ source <sup>*,**</sup>	controlled via its IEC/IEEE-bus interface
Agilent 836x series*	controlled via its IEC/IEEE-bus interface
Agilent ESG series <sup>*,**</sup>	controlled via its IEC/IEEE-bus interface
Anritsu MG369x series <sup>*,**</sup>	controlled via its IEC/IEEE-bus interface
SCPI-compliant RF source*	controlled via its IEC/IEEE-bus interface

\* Not supported for calibration

\*\* Including phase control

## Power Meters

R&S® NRVD	connected to ZVx, requires: - R&S® ZVAB-B44 Option
R&S® NRP-Z series power sensors	connected to ZVx via: R&S® NRP-Z3 (active) USB adapter or R&S® NRP-Z4 (passive) USB adapter
Agilent E4418A	connected to ZVx, requires: - R&S® ZVAB-B44 Option
Agilent N1911A	connected to ZVx, requires: - R&S® ZVAB-B44 Option
Anritsu ML2437A	connected to ZVx, requires: - R&S® ZVAB-B44 Option

---

## Calibration Units

R&S ZV-Z5x series*	connected to ZVx
--------------------	------------------

\* Not supported for on wafer calibration

## Tuners

Please refer to the [NMDG Software Requirements](#) document, for general information about the supported tuner models, and the required software.

## Customization

### Instrument drivers

Drivers for other equipments can be added on customer request.

### External Test sets

External test sets for high power measurement applications (such as high power amplifier measurements) can be added on customer request, with the proper calibration routines.



# Order Information

Designation	Type	Order number
20MHz-24GHz ZVxPlus Kit	NMDG NM310	NM310
2.4mm Adapter Option for NM311 on ZVA50/ZVA67	NMDG NM310-10	NM310-10
20GHz Attenuator Option per port for ZVT8/20 ZVA8/24	NMDG NM310-20	NM310-20
20GHz Attenuator Option per port for ZVA40	NMDG NM310-40A	NM310-40A
20GHz Attenuator Option per port for ZVA50	NMDG NM310-50A	NM310-50A
20GHz Attenuator Option per port for ZVA67	NMDG NM310-67A	NM310-67A
40GHz Attenuator Option per port for ZVA40	NMDG NM310-40B	NM310-40B
50GHz Attenuator Option per port for ZVA50	NMDG NM310-50B	NM310-50B
50GHz Attenuator Option per port for ZVA67	NMDG NM310-67B	NM310-67B
20MHz-24GHz Comb Generator Synchroniser/HPR	NMDG NM211	NM211
3.5mm Connection Kit	NMDG NM311	NM311
2.4mm Adapter Kit for NM311 on ZVA50/ZVA67	NMDG NM311A	NM311A
20GHz Attenuator Kit for ZVT8/20 ZVA8/24/40/50/67	NMDG NM302	NM302
2.4mm Adapter Kit for NM302 on ZVA50/ZVA67	NMDG NM302A	NM302A
40 GHz Attenuator Kit for ZVA40	NMDG NM304	NM304
50 GHz Attenuator Kit for ZVA50	NMDG NM305	NM305



# Trademark Information

Microsoft .NET is a brand associated with Microsoft technology.

The names of actual companies and products mentioned herein may be the trademarks of their respective owners.



# Contact Information

Rohde&Schwarz VNA

[www.rohde-schwarz.com](http://www.rohde-schwarz.com)

ZVxPlus, NM310 and other products and services, focusing on nonlinear RF and HF characterisation, behavioural modelling and test:



Phone: +32 3 890 46 13  
Email: [info@nmdg.be](mailto:info@nmdg.be)  
[www.nmdg.be](http://www.nmdg.be)

February 2012 - Product description and specification are subject to change without notice.